



STRENGTH RATED EXTERNAL
BALUSTRADE SYSTEM
Product, Design, Installation and
Warranty Information



DECK[®]

plus

STRENGTH RATED EXTERNAL BALUSTRADE SYSTEM

Contents

INTRODUCTION	2
COMPONENTS LIST	3
STANDARDS SPECIFICATIONS	3-4
ENVIRONMENTAL CREDENTIALS	5
WARRANTY POLICY	6
DESIGN SPECIFICATION	7
HEALTH & SAFETY/CARE & MAINTENANCE	8
FITTING INSTRUCTIONS FOR THE HORIZONTAL SYSTEM	9-11
FITTING INSTRUCTIONS FOR THE STAIR SYSTEM	12-15
APPENDICES	16-17

STRENGTH RATED EXTERNAL BALUSTRADE SYSTEM

Introduction

Q-Deck Plus® Strength Rated External Balustrade System is a combination of specially selected softwood timber, a special timber to timber connector system and Fastenmaster® timber deck screws.

The timber elements are selected from the existing Q-Deck® range of products, being 44 x 95mm and 38 x 125mm multi-purpose material, 32 x 75mm flat chamfered spindles. These elements have to be used in combination with Q-Deck® 117 x 117mm Grand post material or Grand stop chamfered newels.

TIMBER

High quality kiln dried European redwood (*Pinus sylvestris*), hand selected during manufacture to meet Q-Deck® grading rules. Grand post material is produced from finger jointed European whitewood (*Picea Abies*) and comes C24 strength graded as standard.

PRE-TREATMENT

Q-Deck® products come with a performance warranty (see page 5 for policy details).

This warranty lifespan is achieved by the controlled preservative pre-treatment of our decking products with Tanalith® E wood preservative with a built-in water repellent to provide a long term protection against wood decay and insect attack.



TIMBER TO TIMBER CONNECTOR

The simple two part connector is a fast and robust system for connecting the balustrade rails to the newel posts. Its clever design allows both 90 degree (horizontal) and 35 degree (stair) applications to be achieved with the same connector. It's two part interlocking design and robust composition (polyamide and glass fibre – 10%) make for an immensely strong timber to timber joint that is impervious to water and fire resistant.

The timber to timber connector is fitted to the timber elements using the superior external timber screw, FastenMaster decking screws. These specially coated screws exceeds the demands of (ASTM B-117.5%) salt spray and (FM 4470 & DIN50018) acid rain tests by offering over 1000 hours salt spray and 30 cycles kesterlich.



All tests are carried out on the understanding that neither the Furniture Industry Research Association (FIRA), Hoppings Softwood Products PLC nor it's officers can accept any legal responsibility for information or advice given or opinions whether in response to specific enquiries or otherwise.

Whilst the information is correct at the time of printing, Hoppings Softwood Products PLC reserves the right to make changes without notice.

Hoppings Softwood Products PLC reserves the right to withdraw any product without prior notice.

This publication may only be reproduced for information purposes relating to the specifying and construction of the product system detailed. Written permission must be sought and given by Hoppings Softwood Products for the reproduction of this document for any other use.

STRENGTH RATED EXTERNAL BALUSTRADE SYSTEM

Components

Q-DECK® PLUS STRENGTH RATED EXTERNAL BALUSTRADE SYSTEM FIXING KIT COMPONENTS

For both the horizontal and the stair systems:

- 4x timber to timber connectors.
- 10x 75mm, 40x 40mm & 40x 50mm Fastenmaster deck screws.
- 1 driver bit.
- 2x 1.8m lengths of 44 x 95mm **Q-Deck®** multi-purpose material, for baluster rails.
- 1x 1.8m length of 33 x 120mm **Q-Deck®** multi-purpose material, for top handrail.
- 27 x 69 x 970mm **Q-Deck® Plus** flat chamfered spindle (x10 for horizontal system and x8 for stair system).



Please note: 1500 or 3000mm **Q-Deck® Plus** Grand Stop Chamfered or Grand post material must be used with the above components to complete the system. They can be ordered separately as required.

FITTING INSTRUCTIONS MUST BE ADHERED TO FOR THE SYSTEM TO PERFORM AS TESTED TO BS 6399.

ALL CUTS MADE TO COMPONENTS MUST BE PROTECTED WITH TWO LIBERAL COATS OF ENSELE® END GRAIN BRUSH-ON PRESERVATIVE.

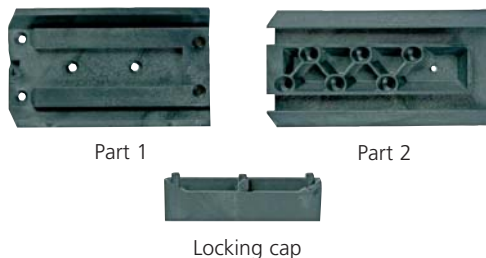

Standards Specification

TESTING (STRENGTH RATING)

Q-Deck Plus® Strength Rated External Balustrade System has been strength tested to BS6180 1999: 'Barriers in and about buildings, by FIRA (Furniture Industry Research Association) International Ltd to meet the requirements set out in BS6399 (1) 1996 'Loadings for Buildings'.

There are two available systems, horizontal and raked (set 35 degrees) both being suitable for 'contract use level' which encompasses commercial areas where

people may congregate such as restaurants and bars (1.5kN/m uniformly distributed load). The horizontal system however passed a higher strength test meaning it is also suitable for 'public access' use which encompasses public areas where people may congregate such as national parks (3kN/m uniformly distributed load). The system can also be used in a domestic situation should the subframe design options allow.

STRENGTH RATED EXTERNAL BALUSTRADE SYSTEM

Standards Specification continued

TESTING (STRENGTH RATING) continued

Test Results (Lateral loading & results)

HORIZONTAL - Q-Deck Plus® strength rated balustrade system (Grand post material as newels at 1800mm centres)

LOADINGS

	Public Access Level	DL x BS 5268: Part 2: 2002 Safety Factor	DL x Q-mark Safety Factor
Load per Meter	3.0kN/m	6.75kN/m	7.5kN/m
UDL Required	550kg	1237kg	1375kg
UDL Achieved	550kg	N/A	N/A
UDL to In-fill	1.5kN/m ²	N/R	N/R
UDL ² Required	1.82kN	N/R	N/R
UDL ² Achieved	182kg	N/R	N/R
PL Balusters Required	0.75 KN	N/R	N/R
PL Balusters Achieved	75kg	N/R	N/R

RESULTS

TEST	TEST REQUIREMENT	RESULT	
Handrail Stiffness	Design Load	Initial Loading	PASS
		Deflection	<20mm
Handrail Strength	BS 5268: Part 2: 2002 Safety Factor	Initial Loading	N/A
		After 15 minutes	N/A
Handrail Strength	Q-mark Safety Factor	Initial Loading	N/A
		After 15 minutes	N/A
Infill Strength	Design Load	Over all Balusters	PASS
Strength of Balusters	BS 5268: Part 2: 2002 Safety Factor	Min 5 Balusters	PASS
	Q-mark Safety Factor	All Balusters	PASS

RAKED/STAIR (35 DEGREES) - Q-Deck Plus® strength rated balustrade system (Grand post material as newels at 1500mm centres)

LOADINGS

	Contract Level	DL x BS 5268: Part 2: 2002 Safety Factor	DL x Q-mark Safety Factor
Load per Meter	1.5/m	3.38kN/m	3.75kN/m
UDL Required	275kg	619kg	687.5kg
UDL Achieved	275kg	N/A	N/A
UDL to In-fill	1.5kN/m ²	N/R	N/R
UDL ² Required	1.82kN	N/R	N/R
UDL ² Achieved	182kg	N/R	N/R
PL Balusters Required	0.75 KN	N/R	N/R
PL Balusters Achieved	75kg	N/R	N/R

TEST	TEST REQUIREMENT	RESULT	
Handrail Stiffness	Design Load	Initial Loading	PASS
		Deflection	7mm
Handrail Strength	BS 5268: Part 2: 2002 Safety Factor	Initial Loading	N/A
		After 15 minutes	N/A
Handrail Strength	Q-mark Safety Factor	Initial Loading	N/A
		After 15 minutes	N/A
Infill Strength	Design Load	Over all Balusters	PASS
Strength of Balusters	BS 5268: Part 2: 2002 Safety Factor	Min 5 Balusters	PASS
	Q-mark Safety Factor	All Balusters	PASS

They are also DeckMark® Plus accredited. DeckMark® Plus is a new initiative from the Timber Decking Association to meet requests from architects and commercial designers for formal performance guidance for the slip resistance rating of deckboard surfaces or the load bearing capabilities of structures like parapets.



No.0325(+)

DeckMark® Plus is an extension of the TDA's DeckMark® quality assurance scheme. Introduced in 2000, DeckMark® was designed to give reassurance to specifiers and consumers that timber deck components have been manufactured to established quality standards. DeckMark® Plus builds on this widely adopted scheme to combine a quality accredited product with a formal performance rating.

For example DeckMark® Plus Strength Rated External Balustrade system now enables architects and designers to specify an external balustrade system that has been independently strength tested in line with BS6399 (1) to provide a 'load bearing' parapet suitable for raised domestic or heavy commercial applications.

STRENGTH RATED EXTERNAL BALUSTRADE SYSTEM

Environmental Credentials

ENVIRONMENTAL ASSURANCE

Q-Deck® Plus Strength Rated Balustrade System is supplied as FSC certified as standard.

The Forest Stewardship Council (FSC) is an independent association that operates to ensure that Forests are well managed. www.fsc-uk.org



By buying Q-Deck® products you are supporting the growth of responsible forest management world wide.

Q-Deck® Plus Strength Rated Balustrade System is manufactured by Hoppings Softwood Products which is a member of the Timber Trades Federation. It is committed to the TTF's Code of Conduct and is a signatory to its Forests Forever Environmental Purchasing Policy which enforces tracability and evidence that raw material is sourced only from sustainably managed forests. They are also signatories to the Timber Trade Federation Responsible Purchasing Policy (RPP). The RPP is a management system, which assesses suppliers for evidence of the legality and sustainability of supply and encourages them to improve.

Hoppings Softwood Products decisions are influenced by the information we obtain from suppliers relating to their environmental practices and the areas from which their raw materials are sourced.

HOPPINGS COMMITMENT TO THE ENVIRONMENT

Respect for the environment is an essential part of our business. We are committed to an environmental purchasing policy, which commits us to exclude from production any material which is:

- Harvested from any area where traditional or civil rights are violated;
- Harvested from uncertified forest having high conservation value where management poses a threat to the high conservation values present;
- Harvested from genetically modified trees;
- Illegally harvested.

This policy is overseen and independently certified by B.M. Trada certification. In addition we are a participant in the Forest Stewardship Council's and PEFC's chain of custody schemes and are able to supply Q-Deck® products as FSC certified and Q-Garden® as FSC & or PEFC certified as standard.

In addition, the company is in full support and a member of Wood for Good.

If you require further information or documentation to confirm the above please don't hesitate to contact us on 0800 8496339.



STRENGTH RATED EXTERNAL BALUSTRADE SYSTEM

Warranty Policy

Q-DECK® TIMBER DECKING & Q-GARDEN® TIMBER COMPONENTS

15 YEAR WARRANTY

Hoppings Softwood Products Plc hereby certify that when fixed appropriately in accordance with the relevant design guidance Q-Deck® timber decking products and Q-Garden® timber products shall be deemed under warranty for 15 years from the date of supply.

CONDITIONS OF WARRANTY

The component shall have been supplied by Hoppings or by an authorised Q-Deck®/Q-Garden® retailer. Proof of date and purchase must be produced to this effect.

Timber should always be treated in its final form. However, any timber exposed by cross-cutting, notching or boring after treatment must be liberally swabbed with two coats of Arch Ensele® brush-on end grain preservative, in accordance with the Arch Code of Practice for Tanalith® E pressure treated timber or the manufacturers instructions. Where possible cross-cut ends must not then be placed in the hazard zone of the design (ie. in ground contact).

The component shall have been fixed in accordance with appropriate guidance enclosed.

EXCLUSIONS OF WARRANTY

- Q-Deck®/Q-Garden® products placed in fresh or salt water contact.
- Q-Deck®/Q-Garden® products supplied for installation outside UK mainland.
- Q-Deck®/Q-Garden® products removed from their original installation and re-used at a new location.
- Degrade caused by poor maintenance or by a material change in the installation environment.
- Failure due to Q-Deck®/Q-Garden® components being used for any purpose for which they were not designed.

TRANSFERABILITY OF WARRANTY

The Q-Deck®/Q-Garden® 15 year warranty is fully transferable to new owners of the installed deck without notification.

UNDERTAKING

The warranty is for the cost of re-supply, by Hoppings, of a component that is proven to have failed as a result of fungal decay or insect attack, FREE OF CHARGE. It does not cover the costs of removal or reinstatement of such components or consequential costs or loss due to failure of the component.

The term 'fungal decay' as used in the warranty refers to wood destroying fungi that feed on and degenerate the wood cell walls. It excludes staining and mould fungi associated with the weathering of wood.

The term 'failed' refers to damage caused by fungi to such an extent that the component is no longer fit for purpose.

STATUTORY RIGHTS

This warranty is in addition to the purchaser's normal statutory rights.

All tests are carried out on the understanding that neither the Furniture Industry Research Association (FIRA), Hoppings Softwood Products PLC nor it's officers can accept any legal responsibility for information or advice given or opinions whether in response to specific enquiries or otherwise.

Whilst the information is correct at the time of printing, Hoppings Softwood Products PLC reserves the right to make changes without notice.

Hoppings Softwood Products PLC reserves the right to withdraw any product without prior notice.

This publication may only be reproduced for information purposes relating to the specifying and construction of the product system detailed. Written permission must be sought and given by Hoppings Softwood Products for the reproduction of this document for any other use.

STRENGTH RATED EXTERNAL BALUSTRADE SYSTEM

Design Specifications

JOIST SPACING (CENTRES)

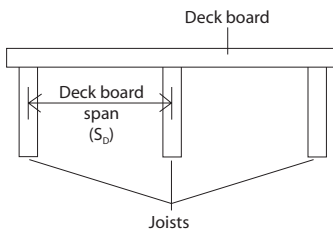

Maximum joist support centres for deck boards
1.5kN/m² - Domestic applications (single occupancy)

Deck board size (mm)	Joist centres (mm) for C16 grade joists - S _D
20.5 x 95	250
27 x 144	500
33 x 120	600

Maximum joist support centres for deckboards
4.0kN/m² - Commercial applications (dining areas, cafes, restaurants, balconies)

Deck board size (mm)	Joist centres (mm) for C16 grade joists - S _D
20.5 x 95	-
27 x 144	400
33 x 120	500

NOTE: This information has been prepared to assist in the preliminary design of timber decks, eg for species selection and initial member sizing. The detailed structural design for an individual deck will need to be confirmed by an appropriately qualified engineer. Reproduced with permission from TRADA (Timber Research and Development Association).

JOIST AND BEAM SPAN TABLES

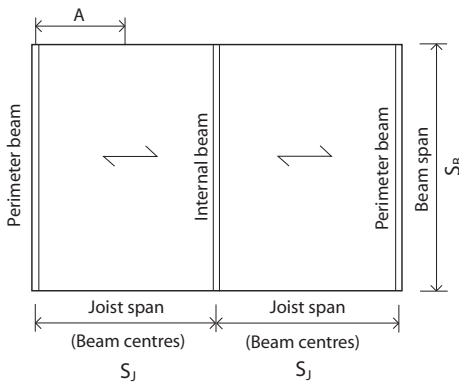

For perimeter beams, A = beam centres = 0.5 joist span

Table A: Maximum joist spans - Strength Class C16

Joist section (mm)	Imposed load 1.5kN/m ² Joist centres (mm)			Imposed load 4.0 kN/m ² Joist centres (mm)				
	width	depth	400	500	600	400	500	600
Maximum clear joist span S_J (metres)								
44 x 97			2.00	1.86	1.75	1.47	1.33	1.22
44 x 122			2.51	2.33	2.20	1.85	1.66	1.51
44 x 147			3.02	2.81	2.64	2.20	1.97	1.80
44 x 170			3.49	3.24	3.05	2.52	2.26	2.07
44 x 195			4.00	3.71	3.50	2.87	2.57	2.35
44 x 220			4.20	4.18	3.94	3.21	2.88	2.63

Table B: Double member beam spans - Strength Class C16

Beam size (mm)	Imposed load 1.5kN/m ² Beam centres (metres)				Imposed load 4.0 kN/m ² Beam centres (metres)					
	width	depth	1.2	1.8	2.4	3.0	1.2	1.8	2.4	3.0
Maximum clear beam span S_B (metres)										
2 x 44	122		1.99	1.72	1.55	1.43	1.45	1.22	1.05	-
2 x 44	147		2.39	2.07	1.87	1.73	1.74	1.46	1.25	1.02
2 x 44	170		2.76	2.40	2.16	1.99	2.02	1.67	1.44	1.18
2 x 44	195		3.16	2.75	2.48	2.29	2.31	1.90	1.64	1.35
2 x 44	220		3.56	3.10	2.80	2.58	2.61	2.13	1.83	1.53

Imposed loads
1.5kN/m² - domestic applications (single occupancy)
4.0kN/m² - commercial applications (dining areas, cafes, restaurants, balconies)

NOTE: The span tables in this document have been prepared to assist in the preliminary design of timber decks, eg for species selection and initial member sizing. The detailed structural design for an individual deck will need to be confirmed by an appropriately qualified engineer.

Reproduced with permission from TRADA (Timber Research and Development Association).

STRENGTH RATED EXTERNAL BALUSTRADE SYSTEM

Health & Safety

- ✓ When handling and processing treated timber always wear gloves and eye protection and work in a well ventilated area.
- ✓ Wash hands thoroughly after handling treated timber and especially before eating or smoking.
- ✓ Do not burn timber off-cuts. Dispose of them safely as refuse. Treated timber contains chemical preservatives.
- ✓ When constructing pergolas keep the surrounding area clear of people until the structure is fully secure.
- ✓ Wear goggles when pressure washing or scrubbing with chemical cleaners or restorers.
- ✓ Keep children away from the work area until the job has been completed and tools have been stored safely.
- ✓ A Consumer Information sheet for TANALISED® E / TANALISED® EXTRA treated timber covering its general use is available from Arch Timber Protection - www.archtp.com.

Care & Maintenance

It is strongly advisable to establish a suitable maintenance programme as soon as the system is completed. As part of this programme regular (weekly preferred if not monthly) inspections should take place to ensure that no component has been damaged or tapered with that could affect the performance of the overall system. The system has an expected service life of approximately 20 years if a maintenance programme has been adhered to. It is strongly advisable to plan to replace the system in its entirety between fifteen and twenty years after original construction.

The balustrade system should be cleaned if and when dirt accumulates. There are many effective cleaning agents available (avoid solvents). Many are useful to remove algae growth which can occur, particularly on any horizontal surfaces and without cleaning this could become unsightly.

Cleaning the balustrade system with a pressure washer at the beginning and end of the season is recommended (or as required). Use a maximum water pressure of 1000 psi. Cleaning the timber to timber brackets with a pressure washer is not advisable.

RE-SEAL

The finished balustrade system should be resealed with a brush-on water repellent every year (or sooner if required) - Hickson Decor WAXCOAT. For best results re-apply water repellent when the deck is dry after pressure washing.

STAIN

Coloured stain can be added to the balustrade system. Please bear in mind the horizontal elements in particular will need more regular re-staining than the vertical elements.

Always follow the manufacturer's instructions when working with deck maintenance products.

TAKE CARE

It is advisable to regularly check for any proud shards or splinters of timber and remove them for safety reasons.

WHAT TO EXPECT

Small surface splits can occur in all components during the warmer months. This happens as the timber dries and shrinks. In the wetter months the splits will tend to close as the timber swells.

REPLACING TOP HAND RAIL

The simplicity of construction means you could easily replace the 33 x 120mm top handrail component should it deteriorate in looks. The 33 x 120mm multi-purpose material is readily available from our national network of Q-Deck stockists as are the Fastenmaster deck screws used in the original assembly.

STRENGTH RATED EXTERNAL BALUSTRADE SYSTEM

FITTING THE HORIZONTAL SYSTEM

See Appendix A and B for overview of the systems measurements.

- A** Attach part 1 of the timber to timber connectors centrally to the faces of the 117 x 117 Grand post material as detailed in image (i) using 6no. 40mm fastenmaster screws at the position detailed in image (ii) below.

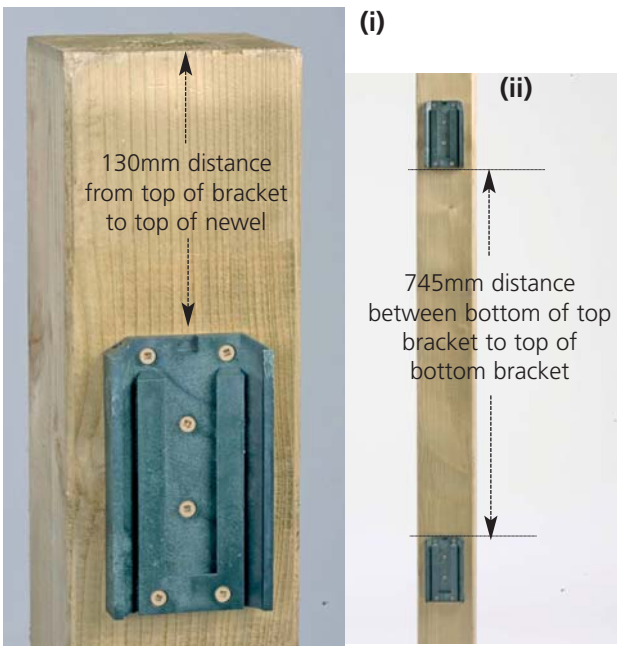
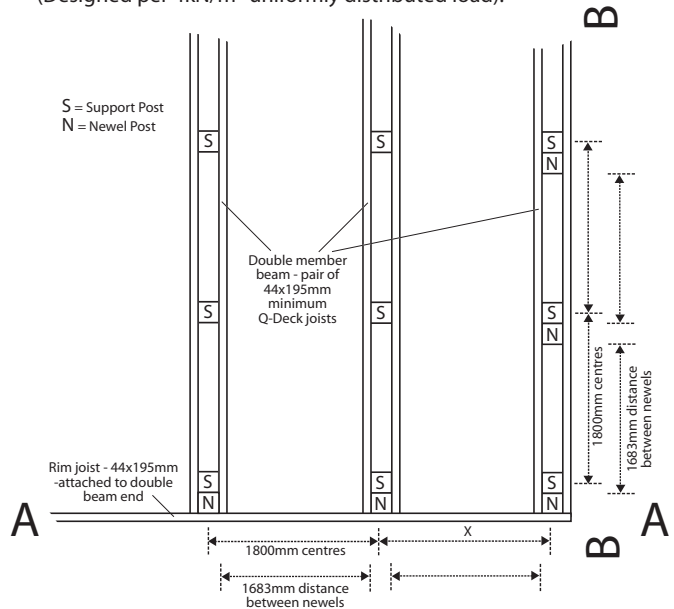

Diagram A

Plan View of Beam Layout

When using the Q-Deck Plus Strength Rated Balustrade System (Designed per 4kN/m² uniformly distributed load).



- B** Attach the newels to the deck frame as detailed in diagrams **A**, **B** and **C** ensuring that the final gap between the top of the decking and bottom of the bottom baluster rail is no more than 100mm and a minimum of 95mm. The newels are to be positioned at centres of 1800mm (maximum).

Ensure the newels are exactly vertical.

Diagram B

Detail of Newel connection to Subframe, section A-A. Two options.

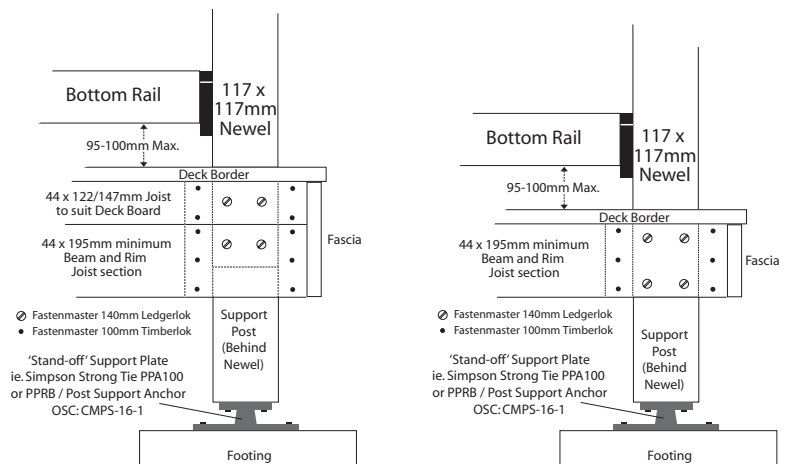

Option 1: Joists on Beams

Option 1: Joists within Beams

STRENGTH RATED EXTERNAL BALUSTRADE SYSTEM

FITTING THE HORIZONTAL SYSTEM

Diagram C

Detail of Newel connection to Subframe, section B-B.
Two options.

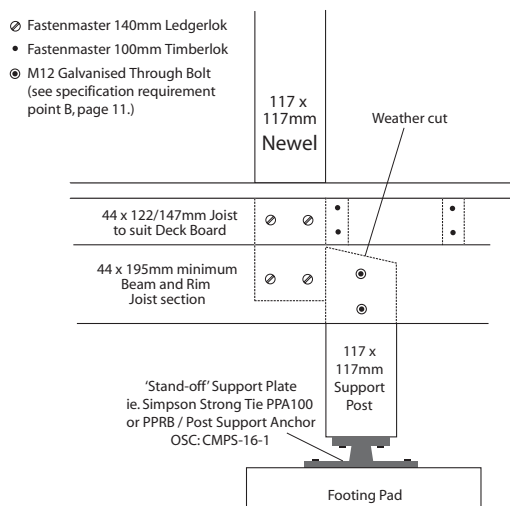

Option 1: Joists on Beams

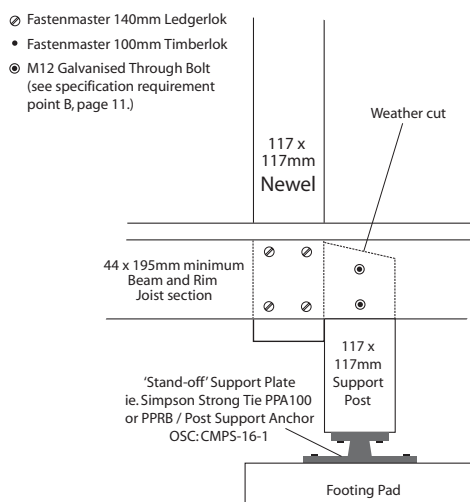

Option 1: Joists within Beams

C Measure the distance between newels and cut the baluster rail (44 x 95mm multi-purpose material) to length allowing for the two timber to timber connectors. At 1800mm post centres this measurement is 1645mm

D Fit part 2 of the timber to timber connectors centrally to the end grain of all the 44 x 95mm baluster rails using 4no. 40mm Fastenmaster screws per connector, as detailed in image (iii), (iv) & (v). Hold the locking cap component of the timber to timber connector temporarily in place in order to reference the correct position of part 2 of the connector to the baluster rail. i.e. the top of the locking cap must be flush with the top of the baluster rail.

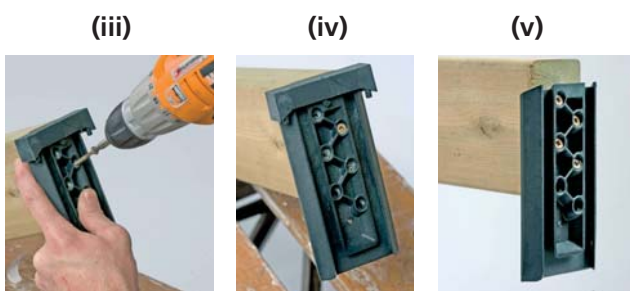

E Using the assistance of another pair of hands slide the top and bottom baluster rails assemblies into position between the newels as detailed in image (vi) and ensure the two parts of the timber to timber connector are fully connected.



(vi)

F Fit the 4 locking caps into position as detailed in image (vii).



(vii)

STRENGTH RATED EXTERNAL BALUSTRADE SYSTEM

FITTING THE HORIZONTAL SYSTEM continued

G Measure the distance between newels and cut the top handrail (33 x 120mm multi-purpose material) to length. At 1800mm (117mm x 117mm Grand Post) post centres this measurement is 1683mm. Fit using 10no. 75mm screws provided in the positions detailed in diagrams **D** and **E**.

Diagram D

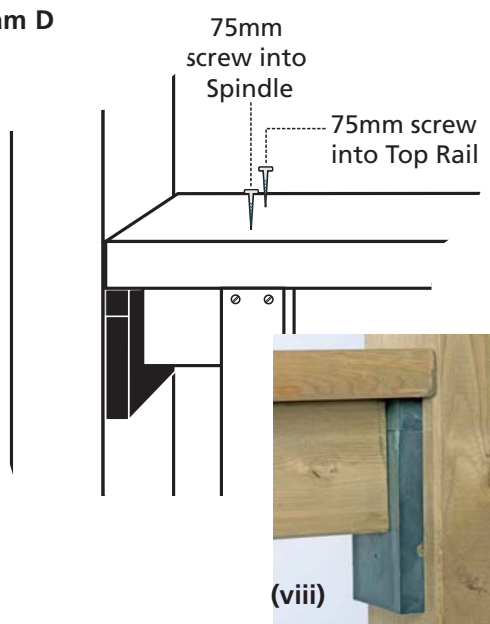
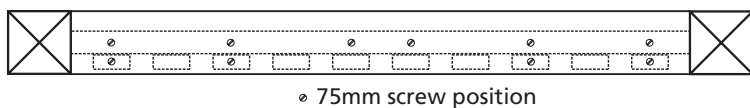

Diagram E



◦ 75mm screw position

H Fit the flat chamfered slats to the **inside ONLY** of the top and bottom baluster rails using 2 no. 50mm Fastenmaster screws at the top and bottom as provided (see images (viii) & (ix) for detail. It is advisable to pre-drill pilot holes for the screws to completely avoid splitting of the grain).

H continued
They should be positioned a uniform distance apart using bespoke spacers (maximum gap between slats should be no more than 100mm). For 1800mm 117mm x 117mm Grand Newel post centres the gap between the 10 spindles provided is 90mm.



I Fit the grand post caps to the top of the newels using 5 generous and symmetrically positioned daubs of a suitable gap filling timber to timber adhesive and allow the adhesive to fully cure (under load) before use.



Finally, check once more that all the screws are tight and that all the components are firmly secure before allowing people to utilise the system.



STRENGTH RATED EXTERNAL BALUSTRADE SYSTEM

FITTING THE STAIR SYSTEM

See Appendix A and B for overview of the systems measurements.

A When designing and constructing stairs always follow the guidelines and stipulations set out in:

- Approved document K of the Building Regulations 1992, Stairs, Ramps and Guards.
- BS5395 Part 1 1977: Stairs, Ladders and Walkways
- BS6180 1982: Code of Practice for Protective Barriers In and About Buildings.

B Attach part 1 of the brackets centrally to the faces of the 117 x 117mm Grand post material as detailed in image (i) using 6no. 40mm fastenmaster screws at the position detailed in image (ii)

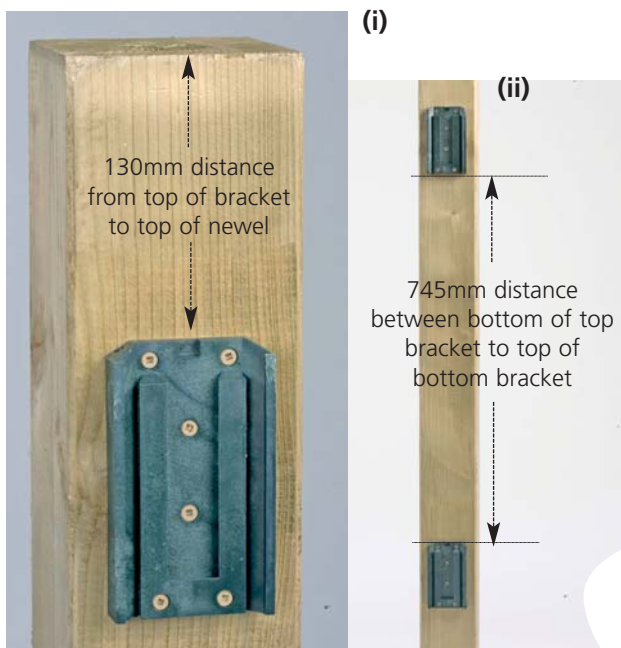

C Attach the newels to suitable stair string material (such as 33 x 266mm UC3 Q-Deck® Plus stair string material). See diagrams A, F, G, H and I.

For decks above 1050mm up to a height of 3150mm (maximum) above ground the stair strings will need mid term support post adding at 1500mm centres. These support posts and the associated newels will need to be attached to the

Diagram A

Plan View of Beam Layout

When using the Q-Deck Plus Strength Rated Balustrade System (Designed per 4kN/m² uniformly distributed load).

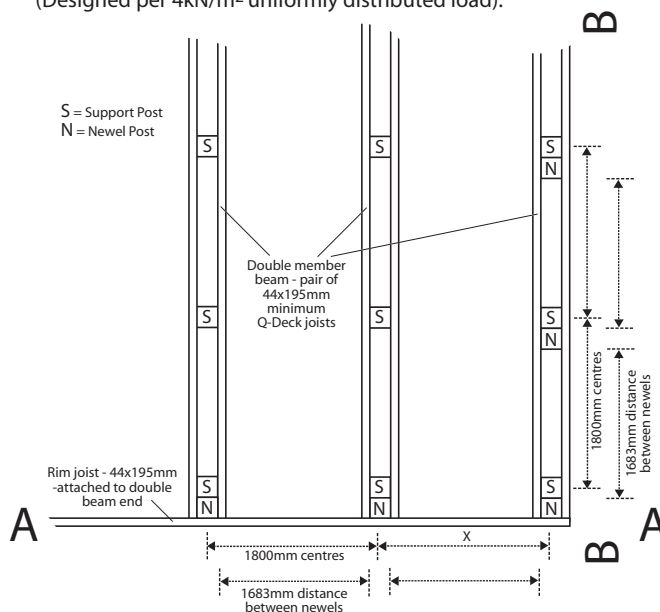
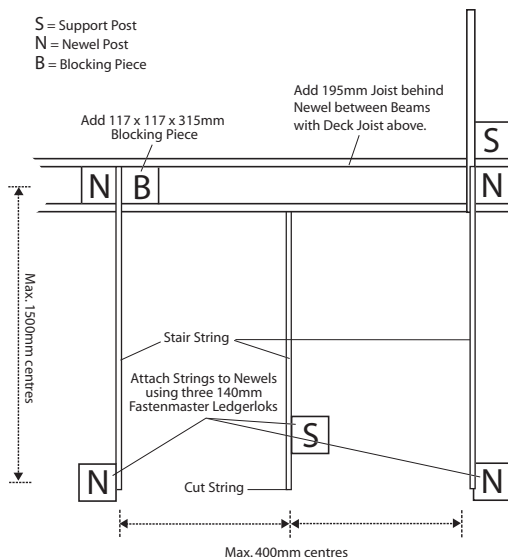

Diagram F

Plan View of Union Between Stair and Subframe, section A-A

(For decks up to 1050mm above ground level).



Note: If stairs can be placed between 900mm centre perimeter beams no blocking pieces are required.

STRENGTH RATED EXTERNAL BALUSTRADE SYSTEM

FITTING THE STAIR SYSTEM

Diagram G

Detail of String connection to Subframe, section A-A

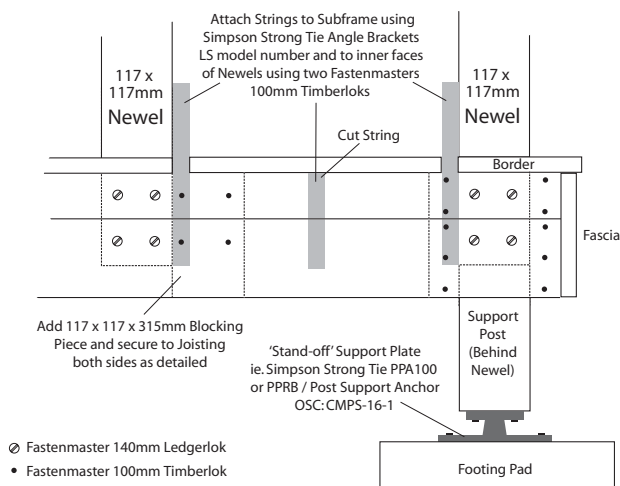

Note: If stairs can be placed between 900mm centre perimeter beams no blocking pieces are required.

Diagram H

Plan View of Union Between Stair and Subframe, section B-B
(For decks up to 1050mm above ground level).

S = Support Post
N = Newel Post
B = Blocking Piece

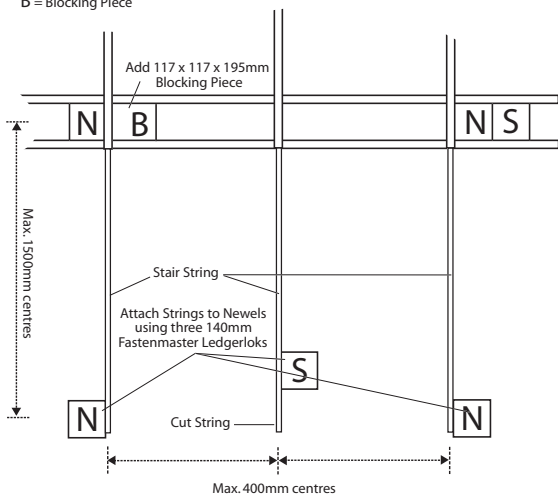

Note: If stairs can be placed between 900mm centre perimeter beams no blocking pieces are required.

Diagram I

Detail of String connection to Subframe, section B-B

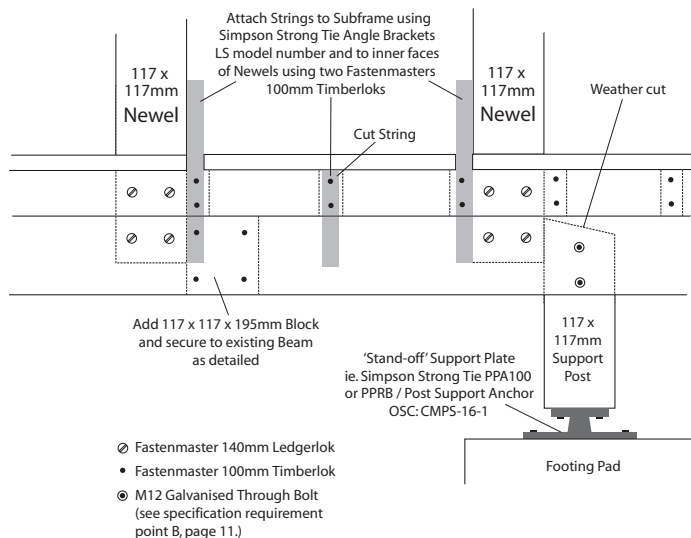

C continued strings using a minimum of 2 hot dipped galvanised (or stainless steel) M12 section through bolts (of at least 4.6 grade mild steel) with plate washers used at either end of the bolt, of 6mm thickness by 72mm diameter.

The bolt centres should be positioned at a minimum of 100mm.

Ensure the newels are exactly vertical.

D Measure the distance between newels and cut the baluster rail (44 x 95mm multi-purpose material) to length at the required 35 degree angle allowing for the two timber to timber connectors.

At 1500mm post centres this measurement is 1642mm between the two parallel 35° angle cuts.

E Fit part 2 of the timber to timber connectors centrally to the end grain of all the 44 x 95mm baluster rails using 4no. 40mm Fastenmaster screws per connector, as detailed in image (iii), (iv) - bottom of rail and (v) - top of rail.

STRENGTH RATED EXTERNAL BALUSTRADE SYSTEM

FITTING THE STAIR SYSTEM *continued*

E *continued*

Hold the locking cap component of the timber to timber connector temporarily in place in order to reference the correct position of part 2 of the connector to the baluster rail i.e. the top of the locking cap must be flush with the top of the baluster rail.



(iii)



(iv)



(v)

F

Using the assistance of another pair of hands slide the top and bottom baluster rail assemblies into position between the newels as detailed in image (vi) and ensure the two parts of the timber to timber connector are fully connected.



(vi)

G

Fit the 4 locking caps into position as detailed in image (vii).



(vii)

H

Measure the distance between newels and cut the top handrail (33 x 120mm multi-purpose material) to length at the desired angles (as detailed in image (viii) (35°) and (ix) (35° and a back cut of 55° ideally – to create a neat fit over the top of the timber to timber connector) At 1500mm (117mm x 117mm Grand Post) post centres this measurement is 1688mm.



(viii)



(ix)



(x)

Image (x) opposite details the desired finish with the face of the newel at the top of the assembly.



(xi)

Image (xi) opposite details the desired finish with the face of the newel at the bottom of the assembly.

I

Fit the top handrail using 8no. 75mm screws provided in the positioned detailed in diagrams J and K below.

Diagram J

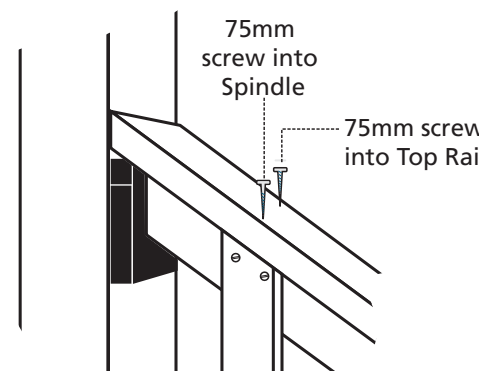
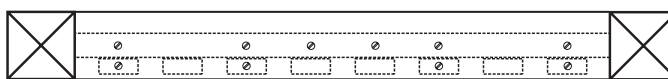

Diagram K



◊ 75mm screw position

STRENGTH RATED EXTERNAL BALUSTRADE SYSTEM

FITTING THE STAIR SYSTEM continued

J Cut the top of the chamfered slats to the desired 35 degree, whilst retaining as much of the original slat length as possible - see image (xii) for detail.



(xii)

Fit the grand post caps to the top of the newels using 5 generous and symmetrically positioned daubs of a suitable gap filling timber to timber adhesive and allow the adhesive to fully cure (under load) before use.



K Fit the flat chamfered slats to the **inside ONLY** of the top and bottom baluster rails using 2 no. 50mm Fastenmaster screws at the top and bottom as provided (see images xiii & xiv for detail). It is advisable to pre-drill pilot holes for the screws to completely avoid splitting of the grain). They should be positioned a uniform distance apart using bespoke spacers (maximum gap between spindles should be no more than 100mm). For 1500mm 117mm x 117mm Grand Newel post centres the gap between the 8 spindles provided is 92mm.



(xiii)



(xiv)

L Finally, check once more that all the screws are tight and that all the components are firmly secure before allowing people to utilise the system.



STRENGTH RATED EXTERNAL BALUSTRADE SYSTEM

Appendix A

Overview of Measurements - Joists on Beams

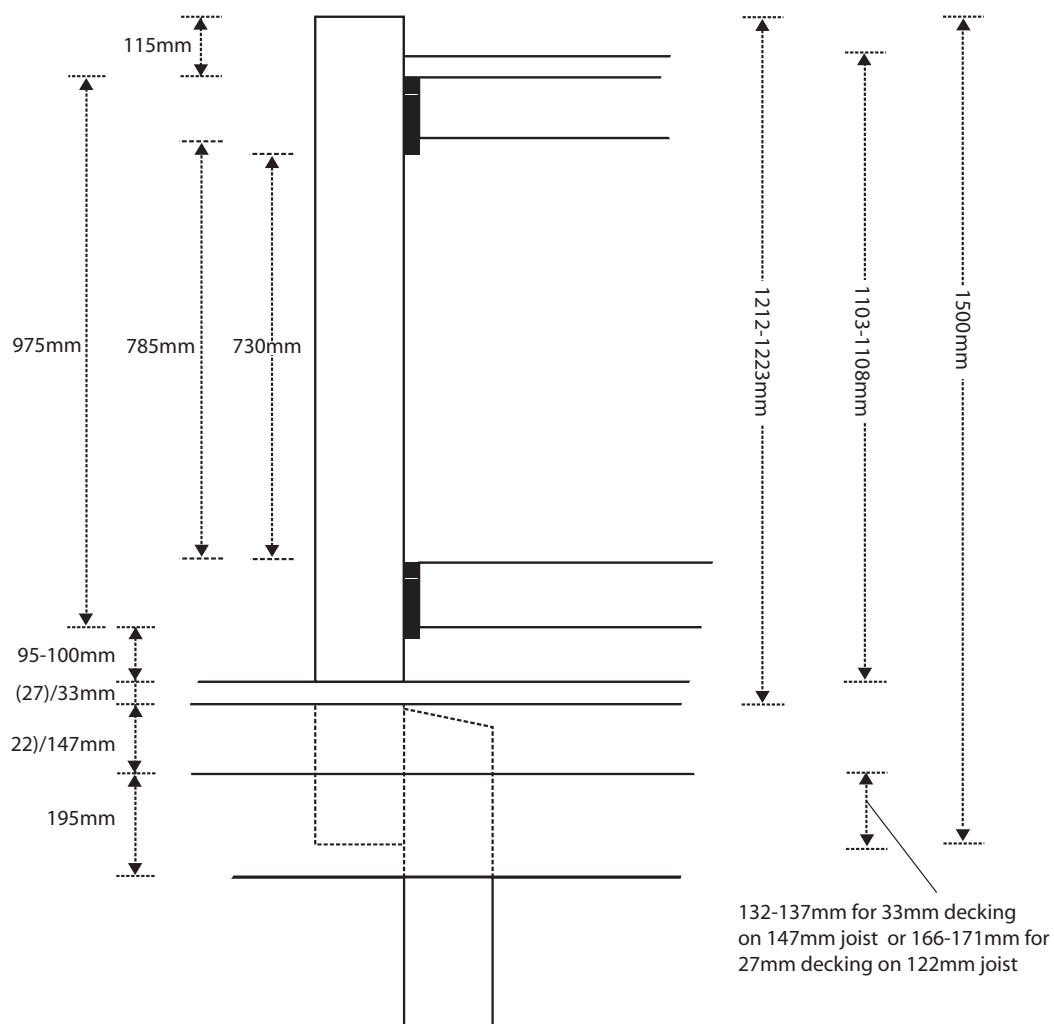

STRENGTH RATED EXTERNAL BALUSTRADE SYSTEM

Appendix B

Overview of Measurements - Joists within Beams

